

MODEL AL or PT-2100

Specifications

Gripping Force–Open and Close, Each Jaw
 @ 100 psi (690 kPa) 29 lbs. (130N)
 Stroke 1.02 in. (26.0mm)
 Weight
 PET 0.38 lbs. (170g)
 AL 0.56 lbs. (252g)
 Operating Displacement. 0.746 in³ (12.2 cm³)
 Maximum Operating Pressure. 120 psi (830 kPa)

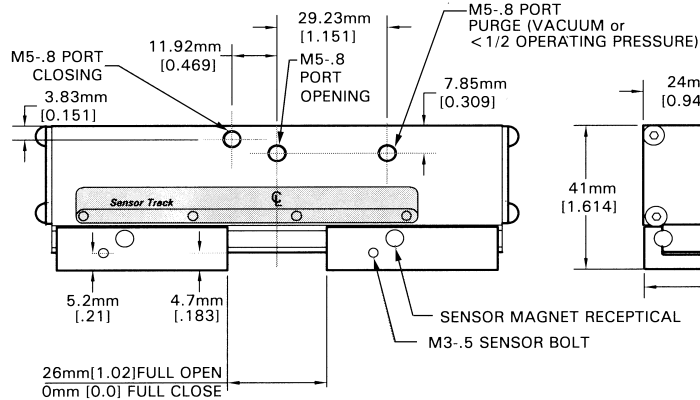

NOTE: All jaw and gripper mounting holes are a minimum of one diameter deep on AL units, one and one half diameters deep on PT units. AL jaw and mounting holes have SS coil inserts. PT maximum torques: .8 Nm [7 in-lb] for 3mm fasteners .9 Nm [8 in-lb] for 4mm fasteners

