

MODEL P-3400

Specifications

Total Stroke	75 mm (3.0 in)
Total Grip Force at 6.2 bar/90 psi	
Open	4580 N (1030 lbf)
Close	4198 N (940 lbf)
Grip Force per Jaw at 6.2 bar/90 psi	
Open	2290 N (515 lbf)
Close	2099 N (470 lbf)
Mass	7.0 kg (15.5 lb)
Bore Diameter	100 mm (3.94 in)
Max. Operating Pressure	8.3 bar (120 psi)

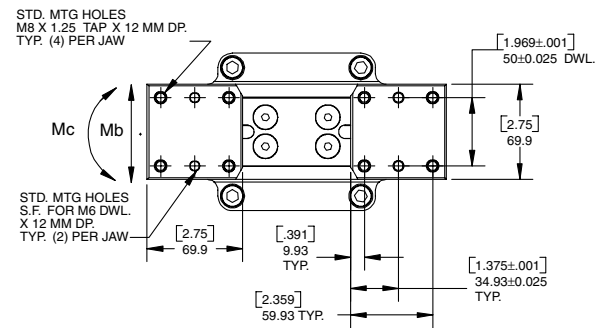
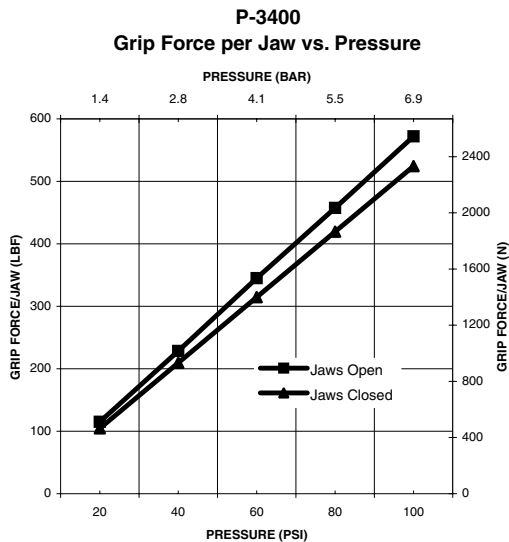
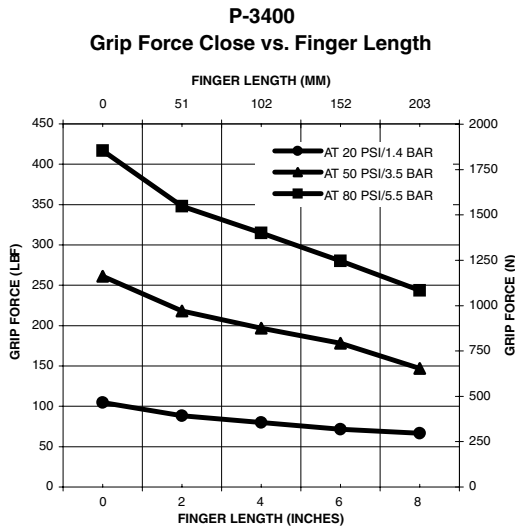
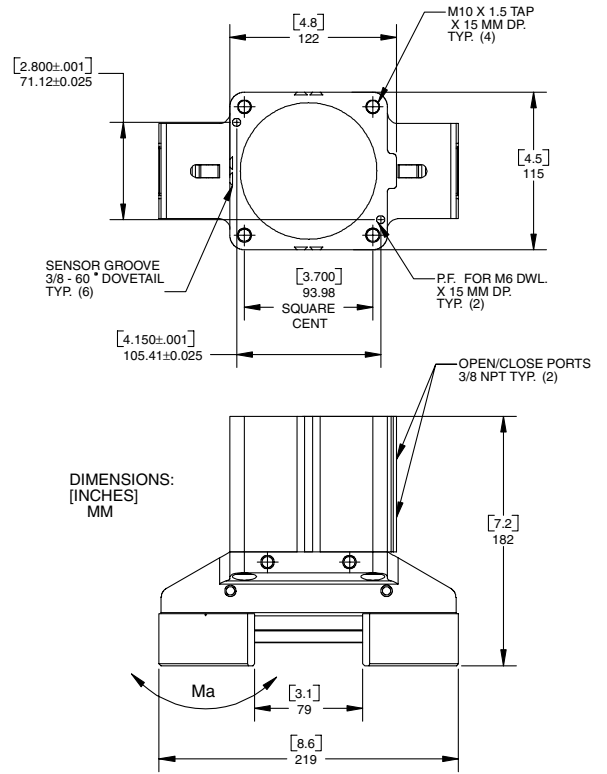

SIDE MOUNT VIEW

